

Case Study - Compressed air efficiency study maximizes effectiveness of existing air system

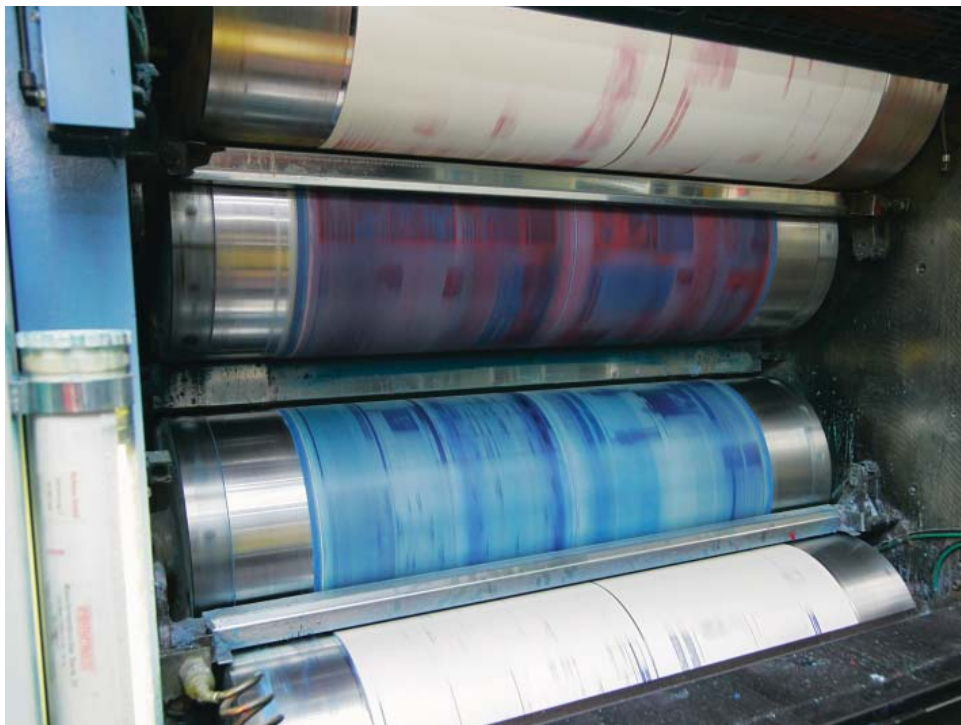

▲
Assessment of leading publishing firm's compressed air system leads to potential investment of nearly \$40K with return on investment realized in less than 2 years.

A large U.S. news publishing firm, with operational costs exceeding \$75,000 per year retained John Henry Foster to perform a complete analysis of their compressed air system. The intent of this evaluation was to maximize the effectiveness of the existing compressed air system and provide recommendations to improve performance, reliability and efficiency over the long term.

CHALLENGES

The compressed air system consisted of six (6) 125 hp rotary screw air compressors operating in a load/no load mode. There is currently no system controller to automatically operate the compressors, causing more compressor horsepower on line than necessary. The average demand was 650 cfm except on Fridays when the average demand climbed to 950 cfm. Demand spikes were recorded periodically at 1,200 cfm for duration of up to 15 minutes. The lack of storage and demand regulation results in both an increase artificial

demand and fluctuating pressure levels. Pressure levels monitored during the study fluctuated between 83 to 122 psi with an average of 111 psi.

SOLUTIONS AND BENEFITS

Recommendations were made for both the supply and demand side of the compressed air system. On the supply side of the system additional storage (3,750 gal.), demand regulation, no air loss drains and a centralized system controller were proposed. The proposed changes to the supply side would provide the following benefits.

- Maintaining a steady 90 psi throughout the header system
- Reduction in leak loss and artificial demand by approximately 21%
- Adequate storage to buffer unexpected loss of an on-line air compressor
- Automatic operation and rotation of air compressors
- Reduction of on-line air compressors
- Reduction in operational and maintenance costs

On the demand side of the compressed air system recommendations included an air leak identification and correction program, replacing open blowing applications with low pressure blowers and energy efficient nozzles. Implementing these recommendations would result in a drastic decrease in air demand.

“
Achieved goal delivered compressed air to main plant distribution system at lowest practical stable pressure.
”

Assessment of leaks and plan of action keeps compressed air system running reliably with low operating costs and higher productivity.

RESULTS

The economic impact of the proposed recommendations would result in a reduction of 63 kW and 372,560 kWh. This would reduce the electrical costs by \$17,196, lowering electrical costs from \$61,238 to \$44,042. A reduction in maintenance costs would be realized in the amount of \$4,500 from less air compressor on-line. When comparing the cost of purchasing and installing additional equipment to the reduction in operational costs a 1.8 year payback would be realized.

Current Plant Layout

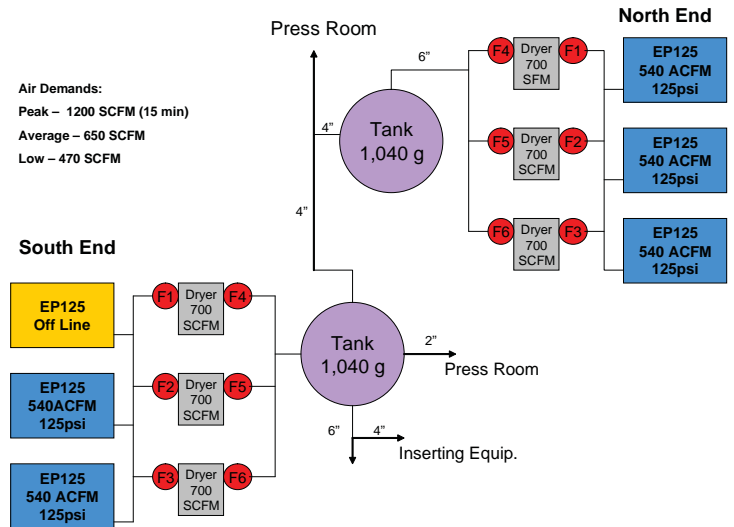

Proposed Plant Layout

